

SÉRIE HV20/25/30

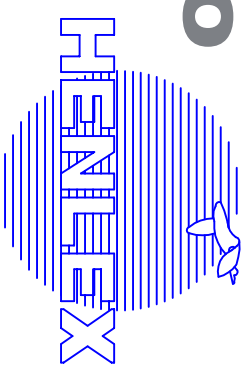

MODÈLE	MOTEUR	DÉBIT MAX.	DÉPRESSION MAX.	Ø ENTRÉE Ø SORTIE
HV20	20-25-30-40 CV	1300 PCM	120 H ₂ O	8"
HV25	40-50 CV	1600 PCM	120 H ₂ O	8"
HV30	50-60 CV	2000 PCM	120 H ₂ O	8"

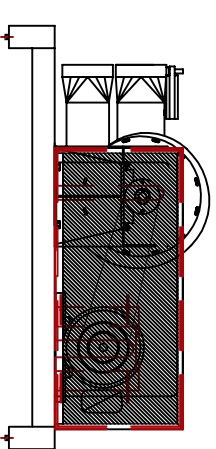

GARDE COURROIE-STANDARD

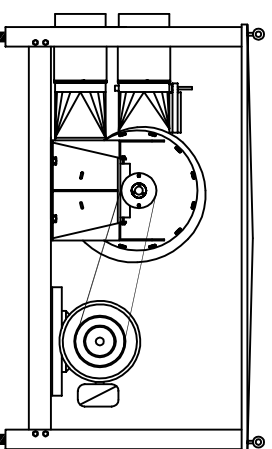
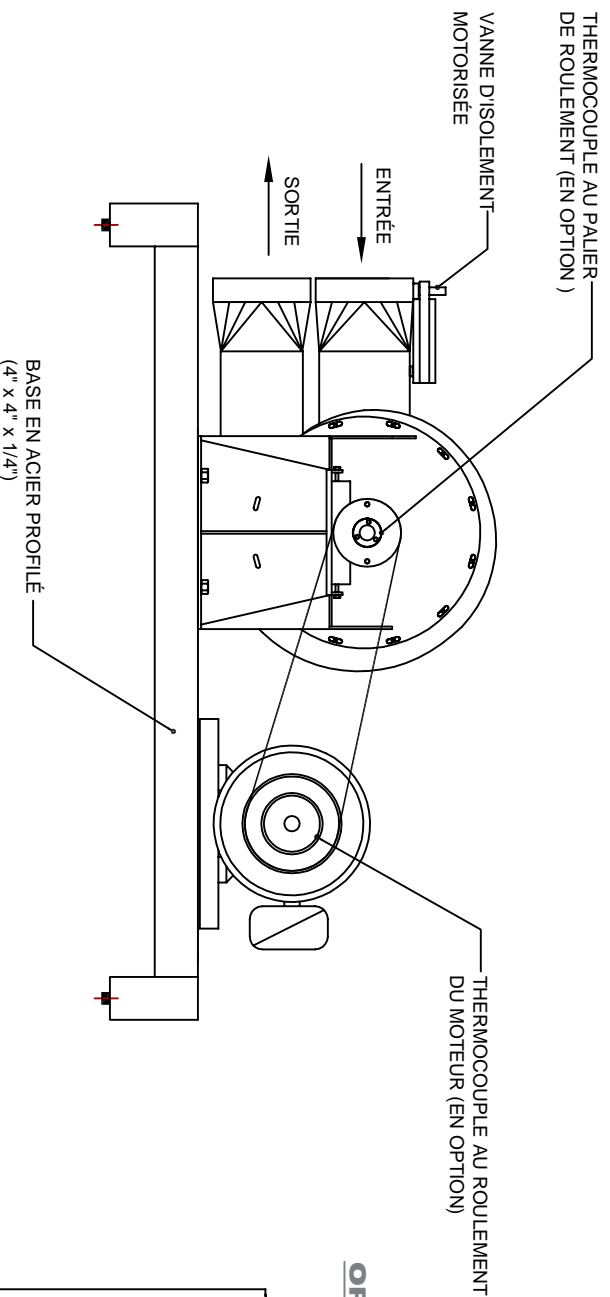

OPTION CABINET ACOUSTIQUE TYPE "H"

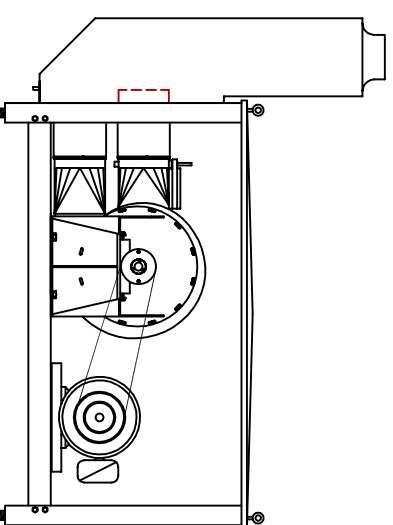

OPTION CABINET ACOUSTIQUE TYPE "HS"